

TOSHIBA BIPOLAR LINEAR INTEGRATED CIRCUIT SILICON MONOLITHIC

TA8470AF/AFG

3 PHASE FULL WAVE BRUSHLESS DC MOTOR DRIVER IC

TA8470AF/AFG is a low-noise type 3 Phase Bi-direction Motor Driver IC, developed as a 3 Phase Hall motor driver for VTRs (capstan, cylinder), etc.

FEATURES

- Operating Voltage Range : $V_{CC} = 7\sim 17\text{ V}$
- Output Current : $I_O (\text{MAX.}) = 1.2\text{ A}$
- Three Phase Bi-direction, current control mode
- Low Noise (Quasi Sinusoidal Drive)
- Built-in FG Amplifier
- Low Output Impedance with B Class Push-Pull Driver, Capable of Short Brakes (Dumping Brakes)
- Position Detecting Circuit (Hall Input) with High Sensitivity : $V_H = 50\text{ mV}_{p-p}$
- Enclosed in Space-saving Power Flat Package
- Built-in Thermal Shutdown Circuit

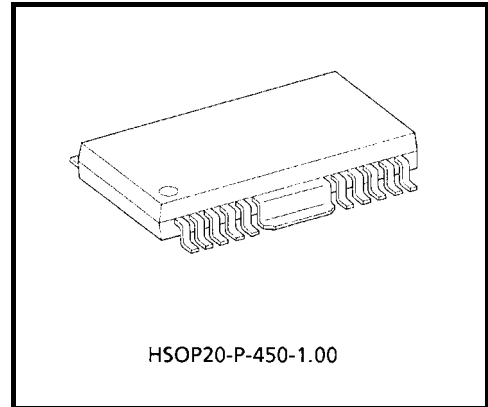

Weight : 0.79 g (Typ.)

TA8470AFG:

The TA8470AFG is a Pb-free product.

The following conditions apply to solderability:

*Solderability

1. Use of Sn-37Pb solder bath
 - *solder bath temperature = 230°C
 - *dipping time = 5 seconds
 - *number of times = once
 - *use of R-type flux
2. Use of Sn-3.0Ag-0.5Cu solder bath
 - *solder bath temperature = 245°C
 - *dipping time = 5 seconds
 - *the number of times = once
 - *use of R-type flux

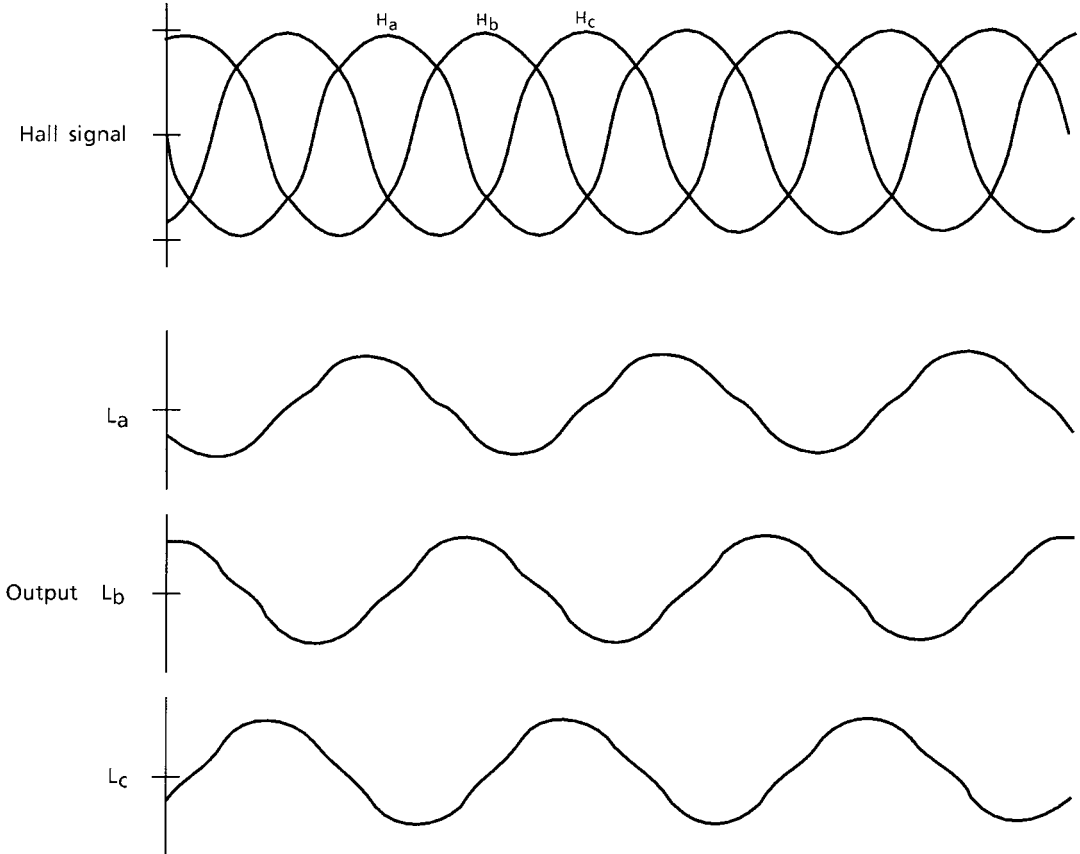

1. Control input circuit

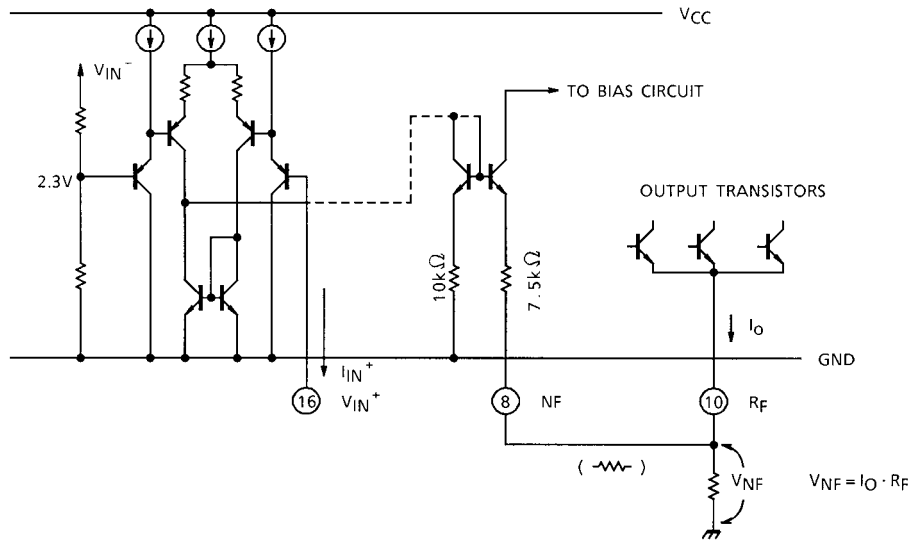

In the case of output current feedback to the motor, connect feedback resistance to RF pin (10) and feed it back to NF pin (8).

The feedback amount can be adjusted by connecting a resistor between pin (10) and (8) pin.

2. FG amplifier and schmitt circuit

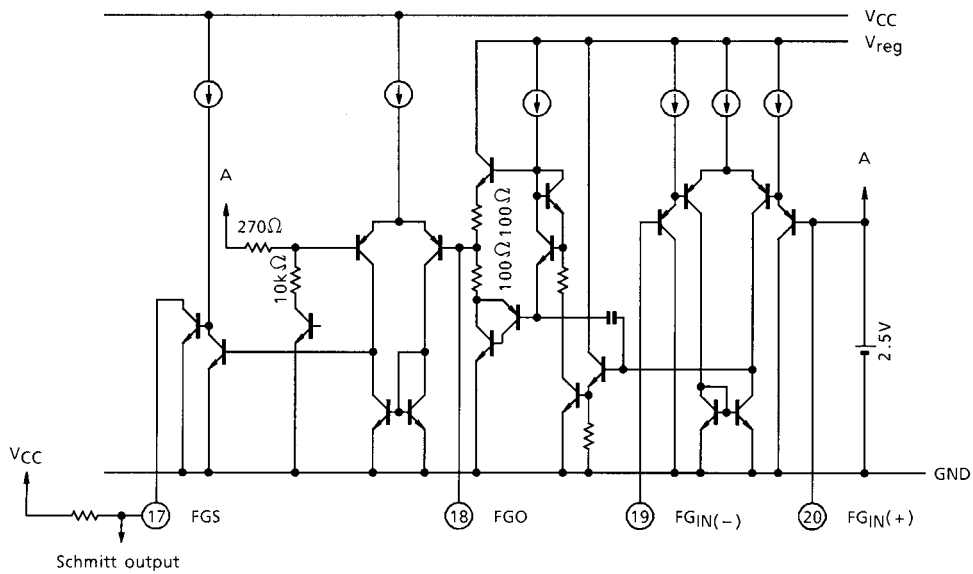

The FG amplifier is stored with internal reference voltage (2.5 V), making it possible to directly input the FG signal from pattern FG. The Schmitt circuit stored within can output wave-shaped FG signals. FGO is in push-pull mode with low impedance.

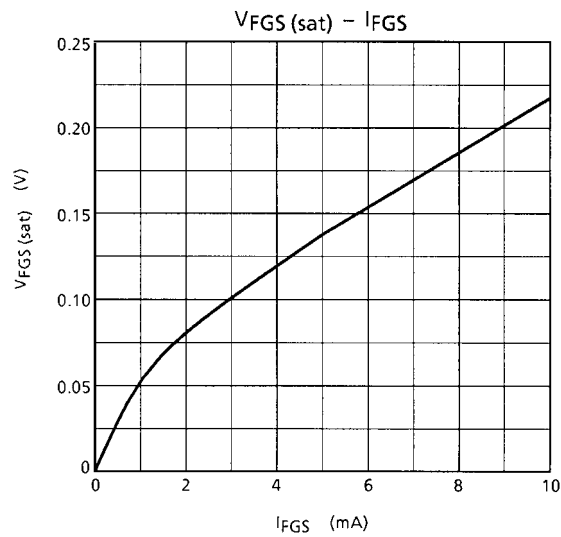

3. FRS section

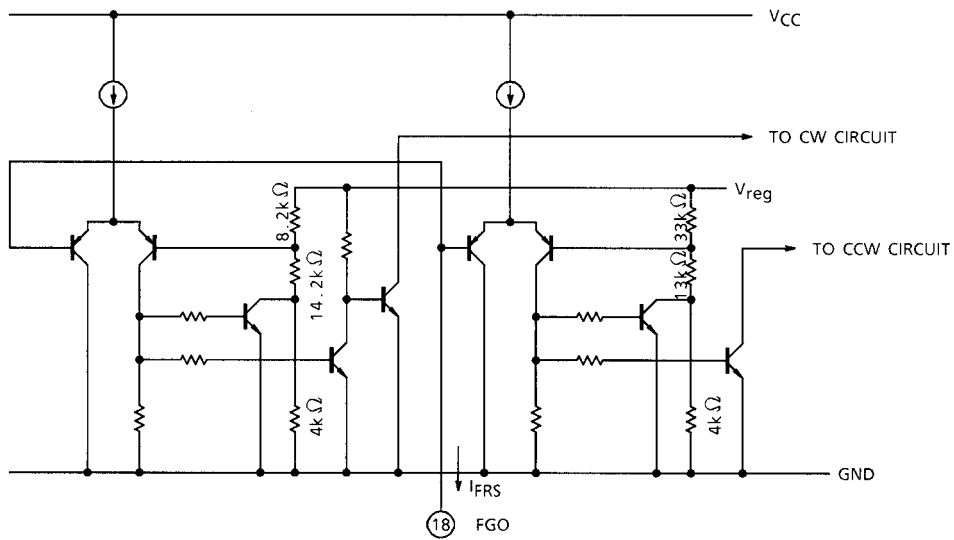

Voltage applied to FRS pin (15) makes it possible to select forward, reverse, and stop modes. For the relationships between FRS, control input, and output, refer to the item on these functions. The relationship between input voltage (V_{FRS}) and input current (I_{FRS}) to the DRS pin (15) is shown as a feature in the following graph :

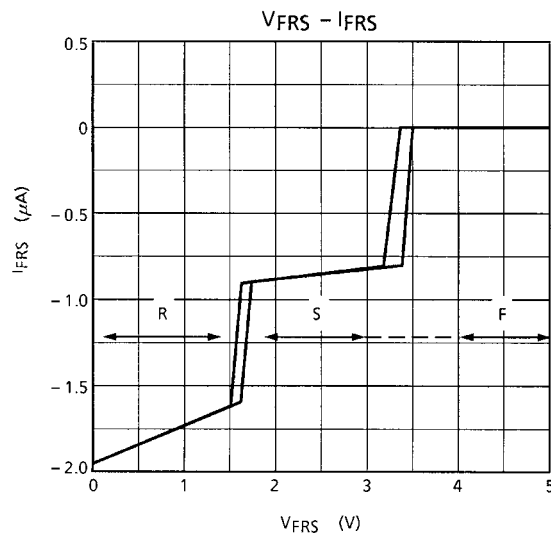

ABSOLUTE MAXIMUM RATINGS (Ta = 25°C)

CHARACTERISTIC	SYMBOL	RATING	UNIT
Supply Voltage	V _{CC}	18	V
Output Current	I _O	1.2	A
FG Output Current	I _{FGO}	12	mA
	I _{FGS}	14	
Power Dissipation	P _D	1.0 (Note 1)	W
		3.2 (Note 2)	
		5.8 (Note 3)	
Operating Temperature	T _{opr}	-30~75	°C
Storage Temperature	T _{stg}	-55~150	°C

Note 1: Without heat sink

Note 2: 50 × 50 × 1 mm Fe board mounting

Note 3: Infinite heat sink mounting

ELECTRICAL CHARACTERISTICS ($V_{CC} = 12\text{ V}$, $V_{IN^-} = 5\text{ V}$, $T_a = 25^\circ\text{C}$)

CHARACTERISTIC		SYMBOL	TEST CIR-CUIT	TEST CONDITION	MIN	TYP.	MAX	UNIT	
Supply Current		I_{CC1}	1	Output Open, FRS = 2.5 V	—	12.5	28	mA	
		I_{CC2}	1	Output Open, FRS = GND	—	14	28		
		I_{CC3}	1	Output Open, FRS = 5 V	—	14	28		
Speed Control Circuit	Input Voltage Range	V_{CIN}	2		GND	—	$V_{CC} - 2.5$	V	
	Control Output Voltage Gain	G_{VCO}	2	$V_H = 25\text{ mV}_{p-p}$	7.5	13	18	dB	
	Input Current	I_{CIN}	2	$V_{IN^+} = \text{GND}$ (Sink Current)	—	0.2	5	μA	
	Internal Reference Voltage 1	V_{ref1}	—		2.15	2.30	2.45	V	
Position Detecting Circuit	Common Mode Input Voltage Range	V_{CMRH}	3		1.5	—	5	V	
	Input Current	I_H	3	$V_{INH} = 2.5\text{ V}$	—	0.2	3	μA	
	Input Voltage Gain	G_{VHO}	4	$V_{IN^+} = 5\text{ V}$	40	47	51	dB	
Output Circuit	Saturation Voltage	Upper Side	$V_{sat(U)}$	5	$I_O = 1.0\text{ A}$	—	1.2	1.9	V
		Lower Side	$V_{sat(L)}$	5	$I_O = 1.0\text{ A}$	—	0.7	1.5	
	Quiescent Voltage	V_{OS}	5	$V_{IN^+} = 1.0\text{ V}$	5.0	5.5	7.0	V	
	Quiescent Voltage Difference	V_{OOF}	5	Each Output to Output	—	25	50	mV	
FG Amp	Open Loop Voltage Gain	G_{VFG}	—	$f_{FG} = 1\text{ kHz}$	—	70	—	dB	
	Band Width	f_{FG}	6		DC	—	50	kHz	
	FGO Output Amplitude	V_{FGO}	6	$I_{FGO} = 5\text{ mA}$	1.0	2.1	4	V	
	FGS Output Saturation Voltage	$V_{sat(FGS)}$	6	$I_{FGS} = 4\text{ mA}$	—	0.15	0.25	V	
	Internal Reference Voltage 2	V_{ref2}	6		2.1	2.5	2.9	V	
	Schmitt Circuit Hysteresis Width	V_{HYS}	6		—	100	250	mV	
Rotation Direction Control Circuit	FWD Operating Voltage	V_{FWD}	5		4.0	—	V_{CC}	V	
	Stop Operating Voltage	V_{STOP}	5		1.9	—	3.1	V	
	Reverse Operating Voltage	V_{REV}	5		0	—	1.3	V	
Thermal Shutdown Operating Temperature		T_{SD}	—		150	—	—	$^\circ\text{C}$	

CHARACTERISTICS OF OUTPUT AMP SATURATION VOLTAGE

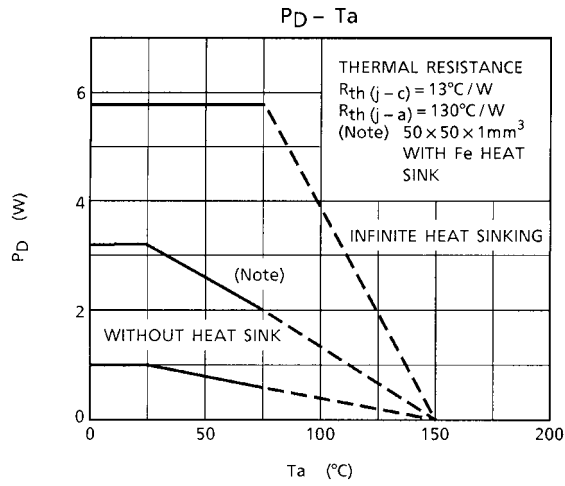
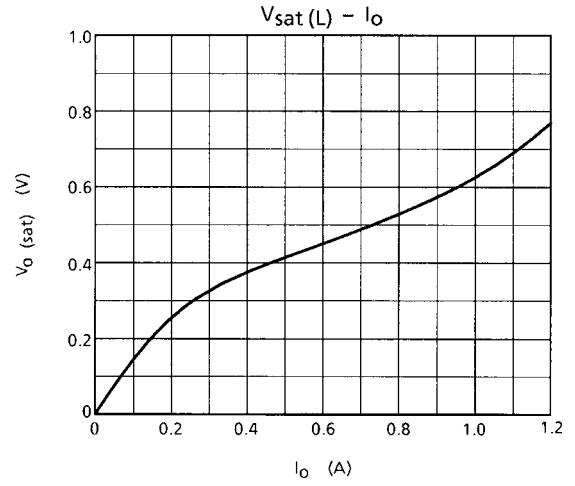
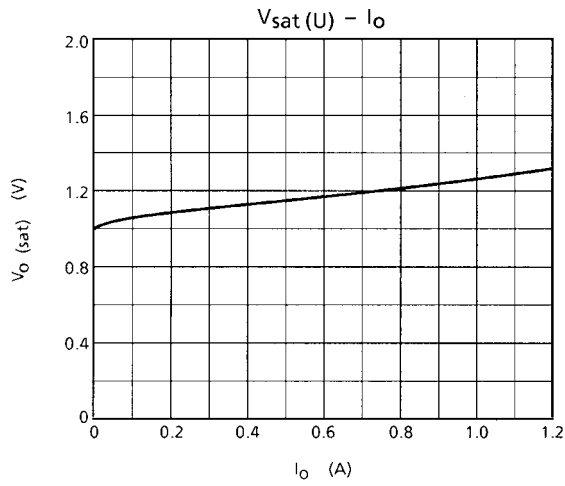

TEST CIRCUIT 1

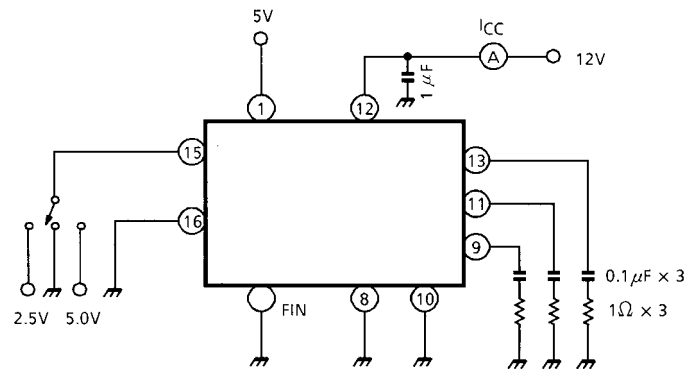

TEST CIRCUIT 2

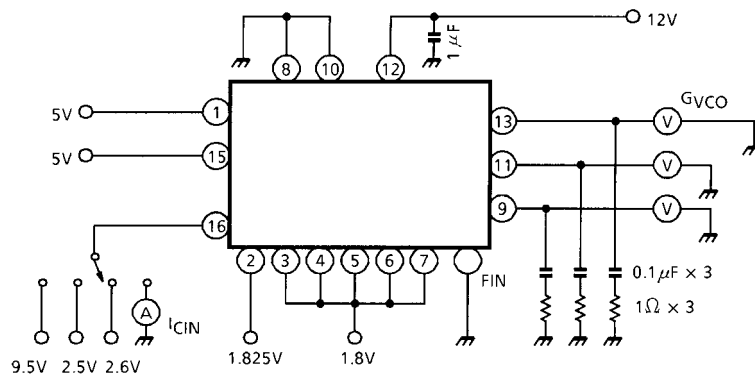

TEST CIRCUIT 3

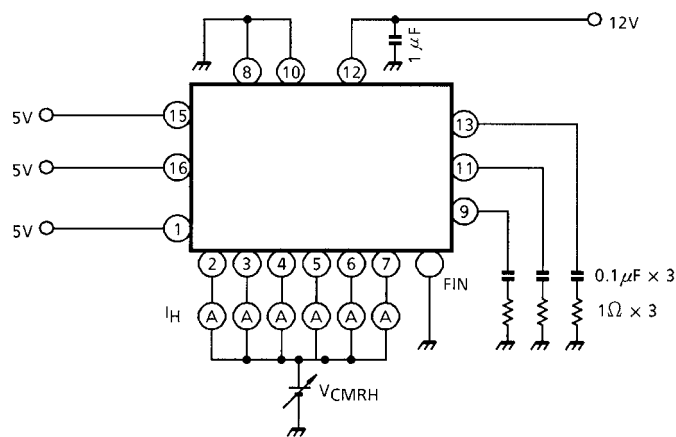

TEST CIRCUIT 4

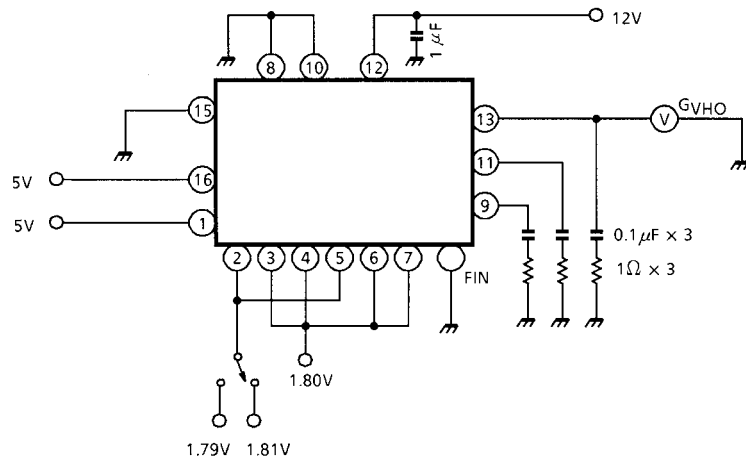

TEST CIRCUIT 5

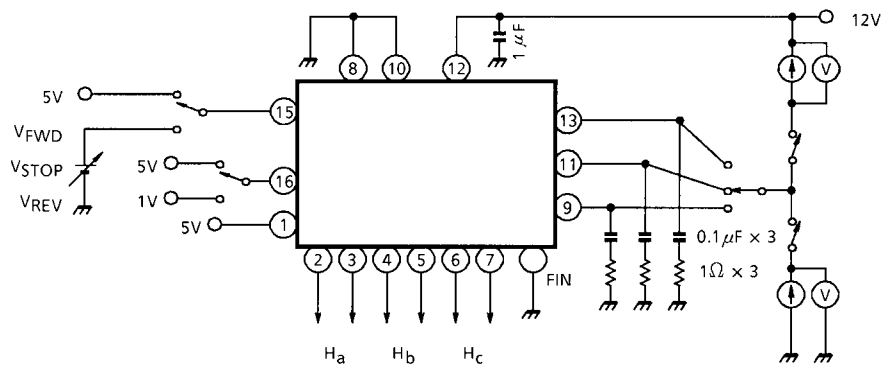

TEST CIRCUIT 6

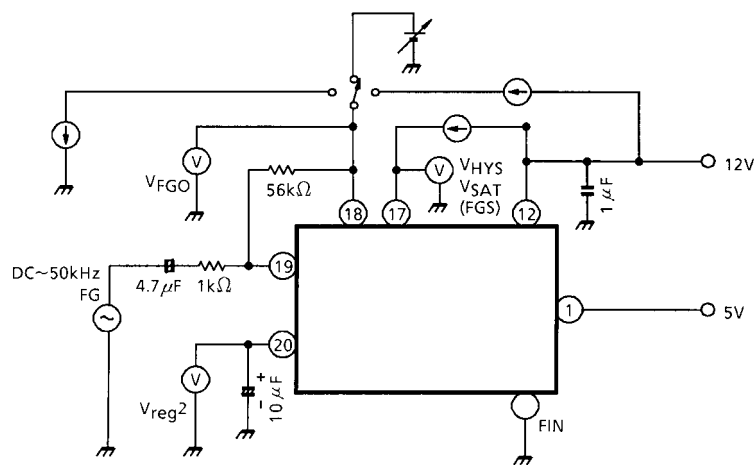

APPLICATION CIRCUIT

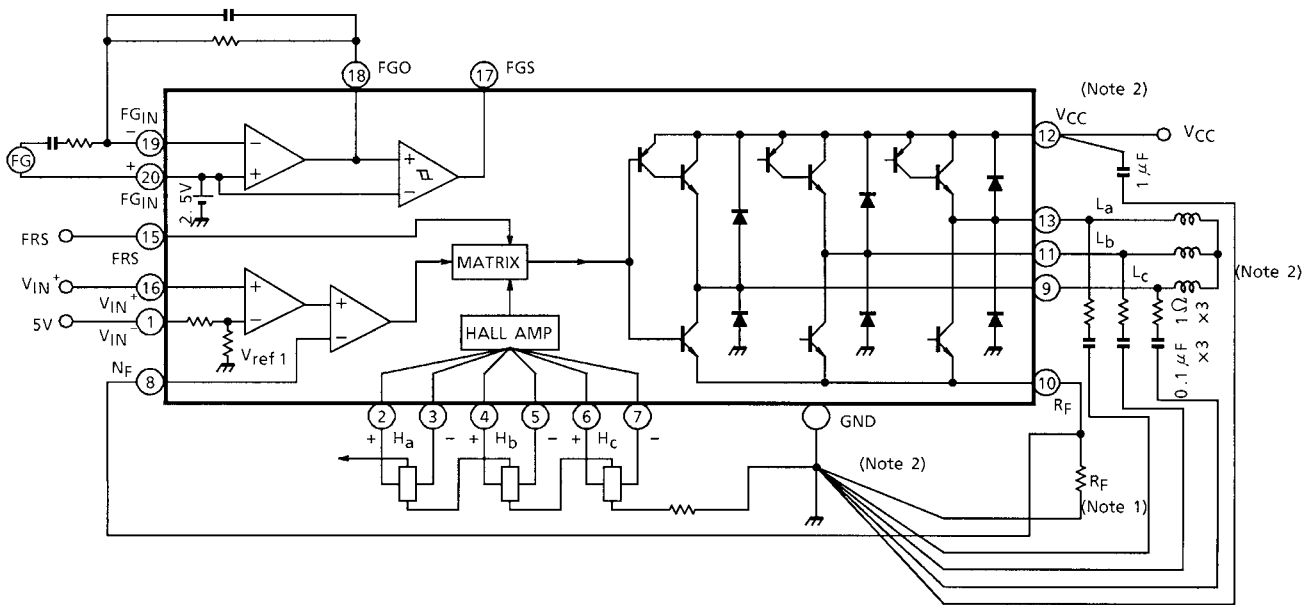

- Note 1: All output currents flow into R_F pins ; therefore, be sure to provide GND separately from other GND lines. Care should be taken not to have common impedance among other GND lines, either, in making pattern designs (especially for Hall Sensor GND line).
- Note 2: Utmost care is necessary in the design of the output, V_{CC} , V_M , and GND lines since the IC may be destroyed by short-circuiting between outputs, air contamination faults, or faults due to improper grounding, or by short-circuiting between contiguous pins.

PACKAGE DIMENSIONS

HSOP20-P-450-1.00

Unit : mm

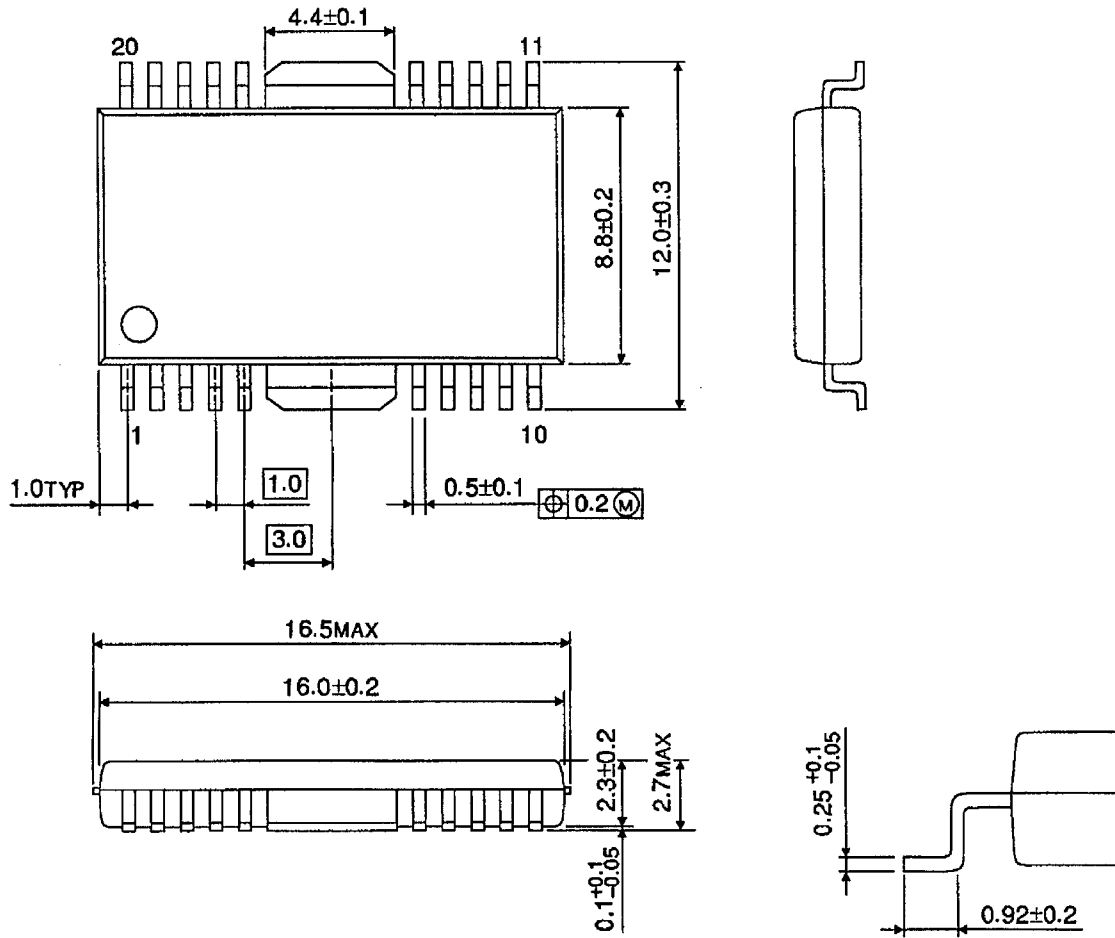

Weight : 0.79 g (Typ.)

Notes on Contents

1. Block Diagrams

Some of the functional blocks, circuits, or constants in the block diagram may be omitted or simplified for explanatory purposes.

2. Equivalent Circuits

The equivalent circuit diagrams may be simplified or some parts of them may be omitted for explanatory purposes.

3. Timing Charts

Timing charts may be simplified for explanatory purposes.

4. Application Circuits

The application circuits shown in this document are provided for reference purposes only. Thorough evaluation is required, especially at the mass production design stage.

Toshiba does not grant any license to any industrial property rights by providing these examples of application circuits.

5. Test Circuits

Components in the test circuits are used only to obtain and confirm the device characteristics. These components and circuits are not guaranteed to prevent malfunction or failure from occurring in the application equipment.

IC Usage Considerations

Notes on handling of ICs

- [1] The absolute maximum ratings of a semiconductor device are a set of ratings that must not be exceeded, even for a moment. Do not exceed any of these ratings.
Exceeding the rating(s) may cause the device breakdown, damage or deterioration, and may result injury by explosion or combustion.
- [2] Use an appropriate power supply fuse to ensure that a large current does not continuously flow in case of over current and/or IC failure. The IC will fully break down when used under conditions that exceed its absolute maximum ratings, when the wiring is routed improperly or when an abnormal pulse noise occurs from the wiring or load, causing a large current to continuously flow and the breakdown can lead smoke or ignition. To minimize the effects of the flow of a large current in case of breakdown, appropriate settings, such as fuse capacity, fusing time and insertion circuit location, are required.
- [3] If your design includes an inductive load such as a motor coil, incorporate a protection circuit into the design to prevent device malfunction or breakdown caused by the current resulting from the inrush current at power ON or the negative current resulting from the back electromotive force at power OFF. IC breakdown may cause injury, smoke or ignition.
Use a stable power supply with ICs with built-in protection functions. If the power supply is unstable, the protection function may not operate, causing IC breakdown. IC breakdown may cause injury, smoke or ignition.
- [4] Do not insert devices in the wrong orientation or incorrectly.
Make sure that the positive and negative terminals of power supplies are connected properly.
Otherwise, the current or power consumption may exceed the absolute maximum rating, and exceeding the rating(s) may cause the device breakdown, damage or deterioration, and may result injury by explosion or combustion.
In addition, do not use any device that is applied the current with inserting in the wrong orientation or incorrectly even just one time.

Points to remember on handling of ICs**(1) Thermal Shutdown Circuit**

Thermal shutdown circuits do not necessarily protect ICs under all circumstances. If the thermal shutdown circuits operate against the over temperature, clear the heat generation status immediately.

Depending on the method of use and usage conditions, such as exceeding absolute maximum ratings can cause the thermal shutdown circuit to not operate properly or IC breakdown before operation.

(2) Heat Radiation Design

In using an IC with large current flow such as power amp, regulator or driver, please design the device so that heat is appropriately radiated, not to exceed the specified junction temperature (T_J) at any time and condition. These ICs generate heat even during normal use. An inadequate IC heat radiation design can lead to decrease in IC life, deterioration of IC characteristics or IC breakdown. In addition, please design the device taking into consideration the effect of IC heat radiation with peripheral components.

(3) Back-EMF

When a motor rotates in the reverse direction, stops or slows down abruptly, a current flow back to the motor's power supply due to the effect of back-EMF. If the current sink capability of the power supply is small, the device's motor power supply and output pins might be exposed to conditions beyond maximum ratings. To avoid this problem, take the effect of back-EMF into consideration in system design.

RESTRICTIONS ON PRODUCT USE

060116EBA

- The information contained herein is subject to change without notice. 021023_D
- TOSHIBA is continually working to improve the quality and reliability of its products. Nevertheless, semiconductor devices in general can malfunction or fail due to their inherent electrical sensitivity and vulnerability to physical stress. It is the responsibility of the buyer, when utilizing TOSHIBA products, to comply with the standards of safety in making a safe design for the entire system, and to avoid situations in which a malfunction or failure of such TOSHIBA products could cause loss of human life, bodily injury or damage to property.
In developing your designs, please ensure that TOSHIBA products are used within specified operating ranges as set forth in the most recent TOSHIBA products specifications. Also, please keep in mind the precautions and conditions set forth in the "Handling Guide for Semiconductor Devices," or "TOSHIBA Semiconductor Reliability Handbook" etc. 021023_A
- The TOSHIBA products listed in this document are intended for usage in general electronics applications (computer, personal equipment, office equipment, measuring equipment, industrial robotics, domestic appliances, etc.). These TOSHIBA products are neither intended nor warranted for usage in equipment that requires extraordinarily high quality and/or reliability or a malfunction or failure of which may cause loss of human life or bodily injury ("Unintended Usage"). Unintended Usage include atomic energy control instruments, airplane or spaceship instruments, transportation instruments, traffic signal instruments, combustion control instruments, medical instruments, all types of safety devices, etc. Unintended Usage of TOSHIBA products listed in this document shall be made at the customer's own risk. 021023_B
- The products described in this document shall not be used or embedded to any downstream products of which manufacture, use and/or sale are prohibited under any applicable laws and regulations. 060106_Q
- The information contained herein is presented only as a guide for the applications of our products. No responsibility is assumed by TOSHIBA for any infringements of patents or other rights of the third parties which may result from its use. No license is granted by implication or otherwise under any patent or patent rights of TOSHIBA or others. 021023_C
- The products described in this document are subject to the foreign exchange and foreign trade laws. 021023_E